

Sidewinder X4 Plus User Manual for 3D Printer

V2.0

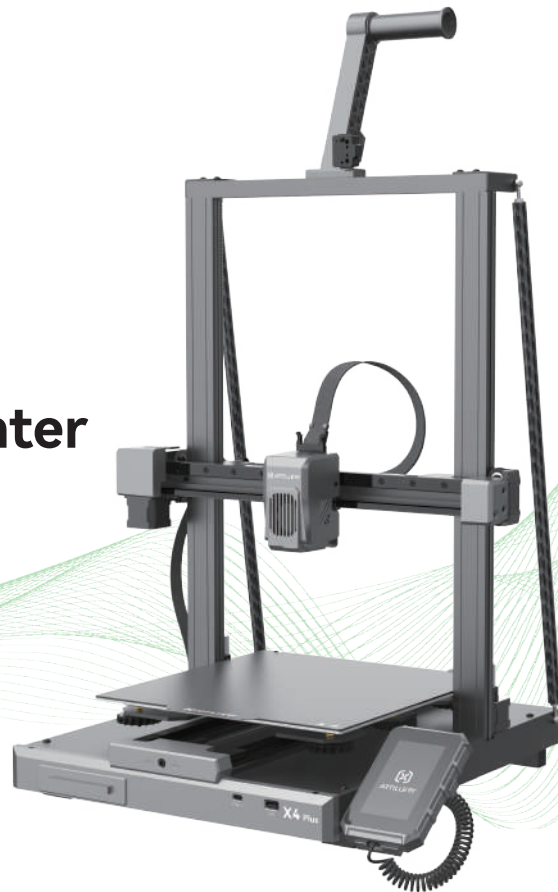

Product Introduction

Thank you for choosing ARTILLERY Products. For your convenience, please read this manual carefully before use, and strictly follow the instructions in the manual. The ARTILLERY team is always ready to provide you with excellent service.

No matter what problems you encounter, please contact us by telephone and email at the end of the manual. In order to enhance your experience with our product, you can also acquire knowledge about equipment operation through the following methods:

Included User Guide: You can find relevant instructions and videos on the USB flash drive.

You can also visit the ARTILLERY official website (www.artillery3d.com) to find information regarding software and hardware, contact details, equipment operation, and maintenance, etc.

Instructions

1. Do not attempt to use the machine in any way that is not described in the user manual to avoid personal injury or property damage.
2. Do not place the machine near flammable or high heat sources. Instead, place it in a well-ventilated, cool, and dust-free environment.
3. Do not place the printer in a vibrating or unstable environment, as machine vibrations can affect print quality.
4. It is recommended to use consumables recommended by the manufacturer to avoid nozzle clogging and machine damage.
5. Do not use other power cords during installation. Please use the power cord provided with the machine and plug it into a three-hole socket with grounding.
6. Do not touch the nozzle or hotbed while the printer is in operation to prevent burns and personal injury.
7. Do not wear gloves or loose clothing while operating the machine to prevent entanglement or injury from moving parts.
8. After completing a print, clean the residue on the nozzle using tools while taking precautions not to touch the hot nozzle with bare hands.
9. Regularly maintain the printer by cleaning the machine body with a dry cloth, removing dust and adhered printing materials or foreign objects from the guide rails while the power is off.
10. Children under the age of 10 should not use the machine without supervision to avoid personal injury.
11. Users must comply with relevant national and regional laws and regulations, adhere to professional ethics, and fulfill safety obligations. It is strictly prohibited to use our products or equipment for any illegal purposes. Our company takes no responsibility for any legal liabilities resulting from violations.
12. In case of emergencies, please turn off the power directly.

CONTENTS

01. Equipment Information	01-03
1.1 Introduction	01-01
1.2 Specifications	02-02
1.3 Packing List	03-03
02.Unboxing Operation	04-06
2.1 Product Installation	04-06
03.Introduction to the Equipment Screen Interface	07-12
3.1 Common Interfaces	07-07
3.2 Common Functions	08-09
3.3 Boot Guide	10-10
3.4 Leveling Settings	11-12
04.Printing for The First Time	13-18
4.1 Software Configuration	13-15
4.2 Printing Files	16-17
4.3 WIFI Connection Printing	18-18
05.Machine Function Explanation	19-20
5.1 Feed	19-19
5.2 Material Retraction	20-20
06.Warmly Reminding and Daily Maintenance	21-24
6.1 Printing Precautions	21-22
6.2 Maintenance Projects	23-23
6.3 Legal Explanation	24-24

1. Equipment Information

1.1 Introduction

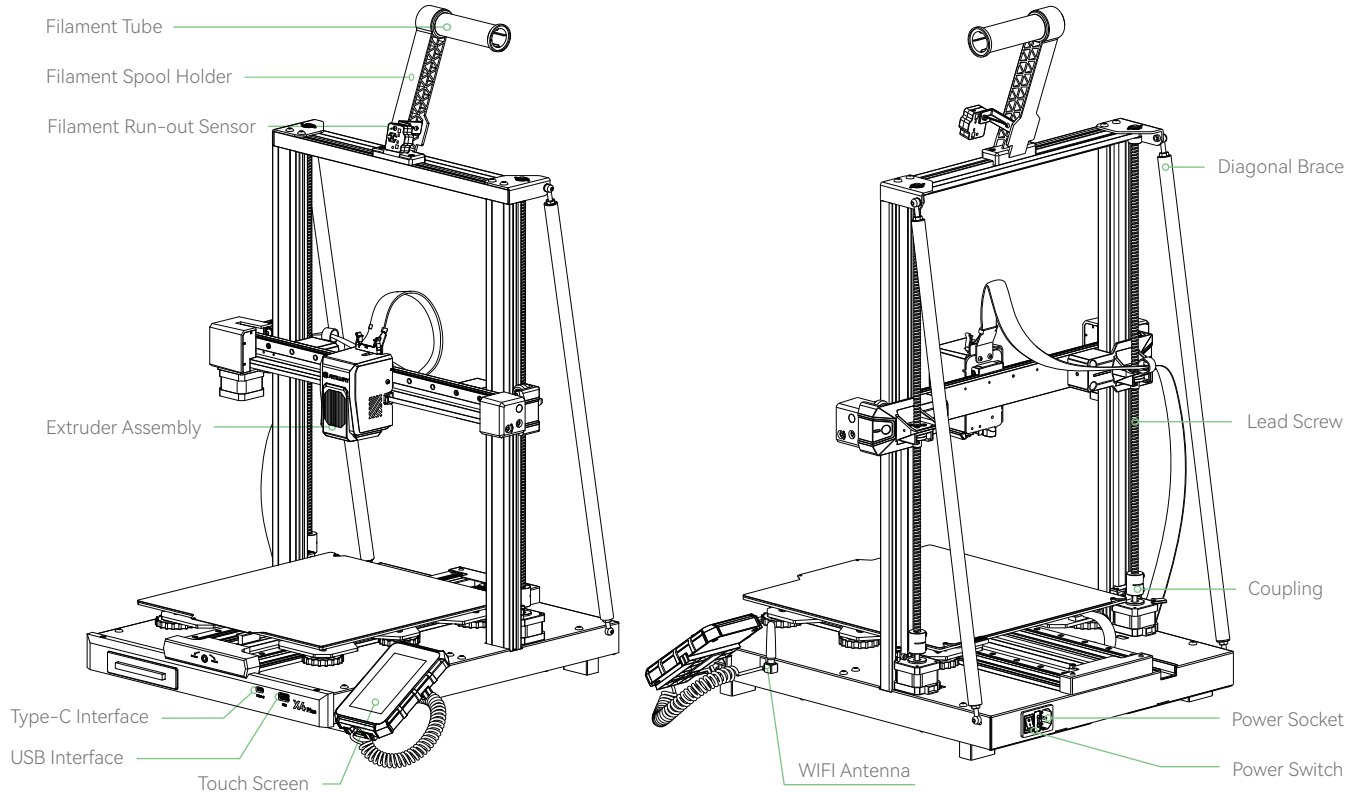

1. Equipment Information

1.2 Specifications

Basic Specification	
Product Model	Sidewinder X4 Plus
Machine Dimensions	510mm*490mm*680mm
Printing Size	300mm*300mm*400mm
The Principle of Printing	FDM
Print Speed	≤500m/s
Nozzle Diameter	0.4mm
Operating Environment Temperature	10-30 °C
Type of Extruder	Proximal Extrusion
Compatible Materials	PLA/TPU/PETG/ABS/PET/Carbon
Maximum Nozzle Temperature	300°C
Maximum Heated Bed Temperature	4.3 inch Touch Screen
Screen	100°C
Printing Method	U disk/WIFI
Auto-leveling	Support
Power-off Resume	Support
Filament Run-out Detection	Support

1. Equipment Information

1.3 Packing List

List of main parts and components:

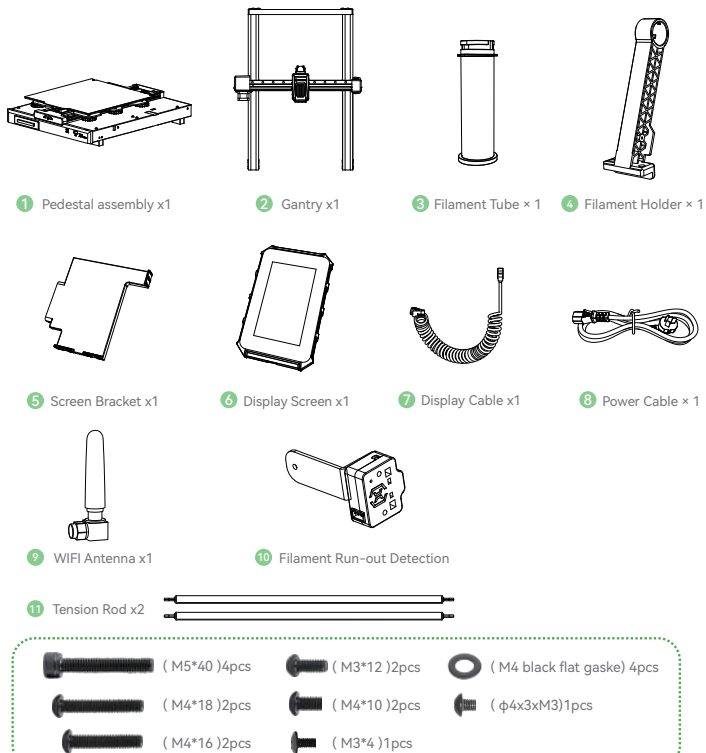

List of accessories and tools:

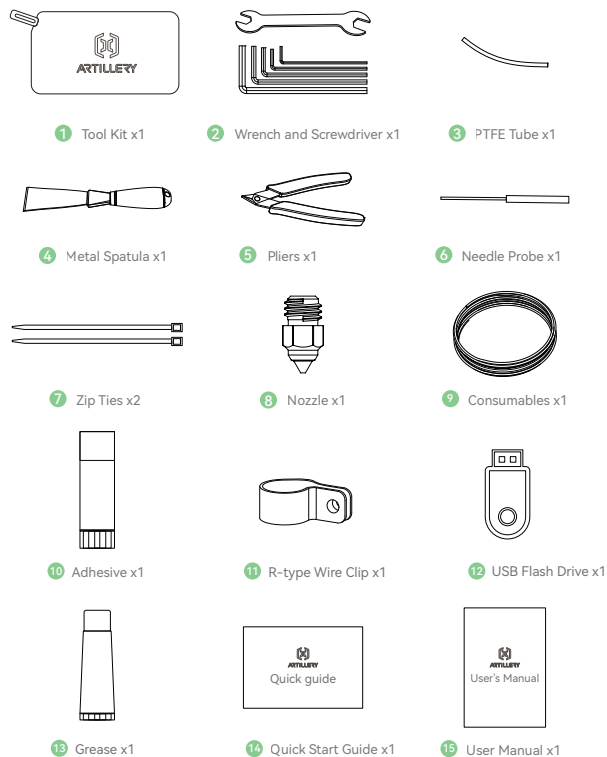

2. Unboxing Operation

2.1 Product Installation

- 1 Insert the gantry into the slot on the base. Ensure that the gantry direction matches the bottom slot direction.

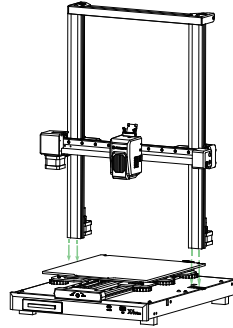

- 2 Use four M5*40 screws (screw bags ①) to lock the gantry on the base. When locking the screws, make sure to keep the profile close to the inside and then lock it to prevent the appearance of external eight characters.

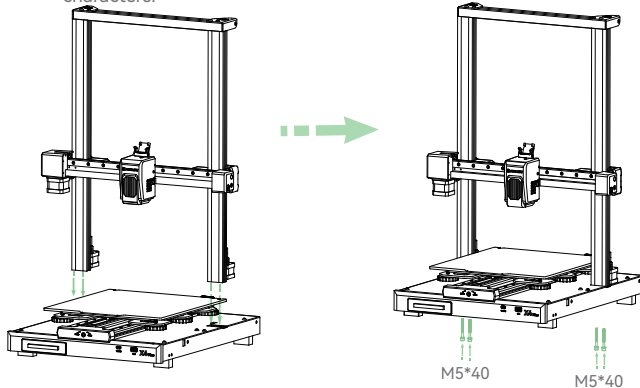

- 3 Assemble the material rack assembly as shown in the following figure: Thread the material pipe through the material rack and tighten it, and then install the broken material detector assembly on the right side of the material rack with one $\phi 4 \times 3 \times M3$ screw (screw bags ②).

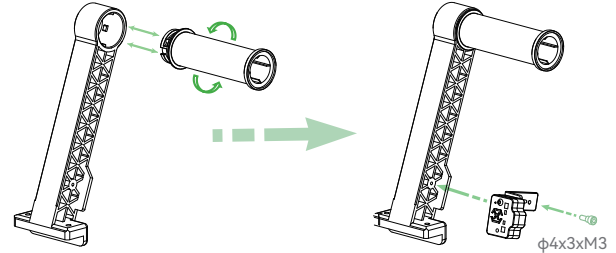

- 4 Install the rack assembly to the top cross member using two M4*18 screws (screw bags ③).

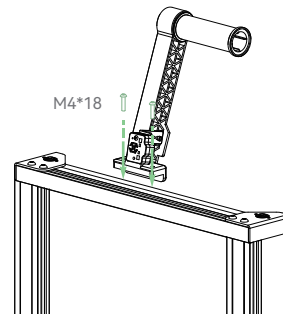

2. Unboxing Operation

- 5 Fix the screen bracket on the right side of the machine with two M3*12 screws (screw bags④) (as shown in Figure a); Connect both ends of the telephone line to the right side of the machine and the screen port respectively (as shown in Figures b and c); Place the display screen on the screen bracket. Connect the WIFI antenna (as shown in Figures d and e).

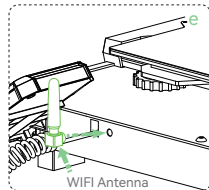
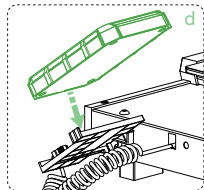
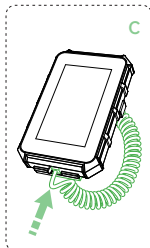
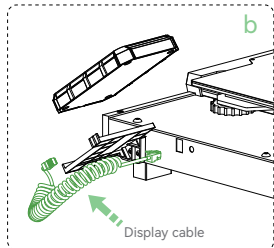
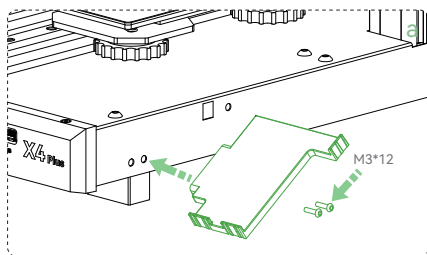

- 6 Insert the 3pin line of broken material detection into the broken material detection port; Then insert the 2pin line of the top LED lamp into the LED lamp port; Finally, insert the 4pin wire of the motor into the motor ports on both sides of the Z axis.

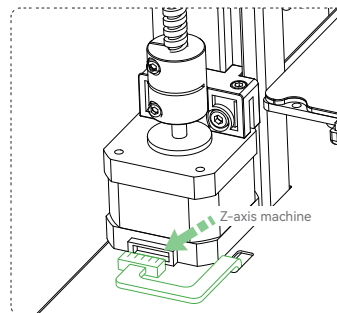
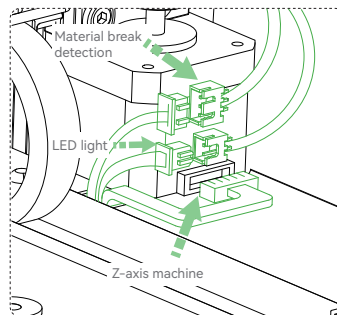

2. Unboxing Operation

- 7 Insert the flat cable from the fixed sheet metal part and then insert it into the horn head port at the top of the extrusion head.
- 9 Insert the 6pin wire of the motor into the X-axis motor port.

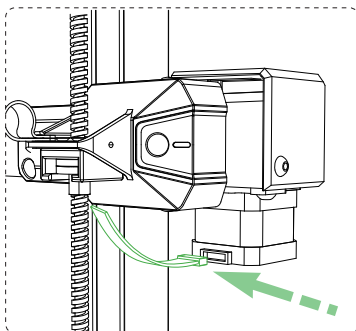
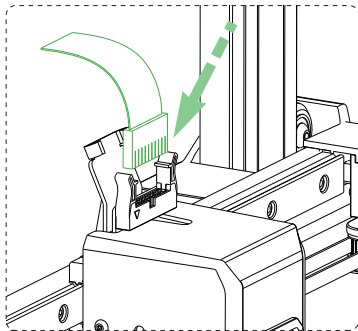

- 8 Use one M3*4 screw (screw bags ⑤) to fix the R-type clamp at the rear end of the X-axis fixture.

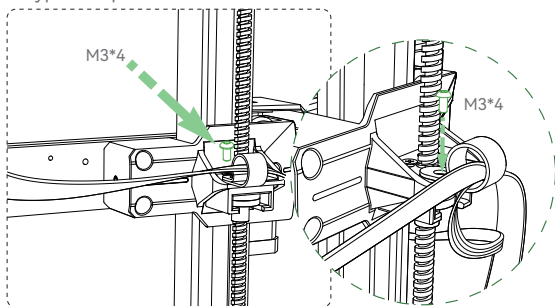

- 10 Use two M4*10 screws (screw bags ⑥) to fix the upper end of the inclined tie rod, and then use two M4*16 screws (screw bags ⑦) to fix the lower end of the inclined tie rod. (4 M4 gaskets should be added during installation to prevent loosening.)

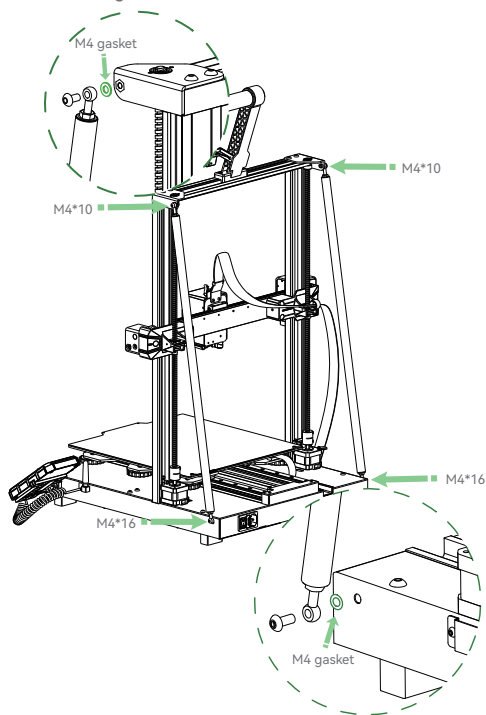

3. Introduction to the Equipment Screen Interface

3.1 Common Interfaces

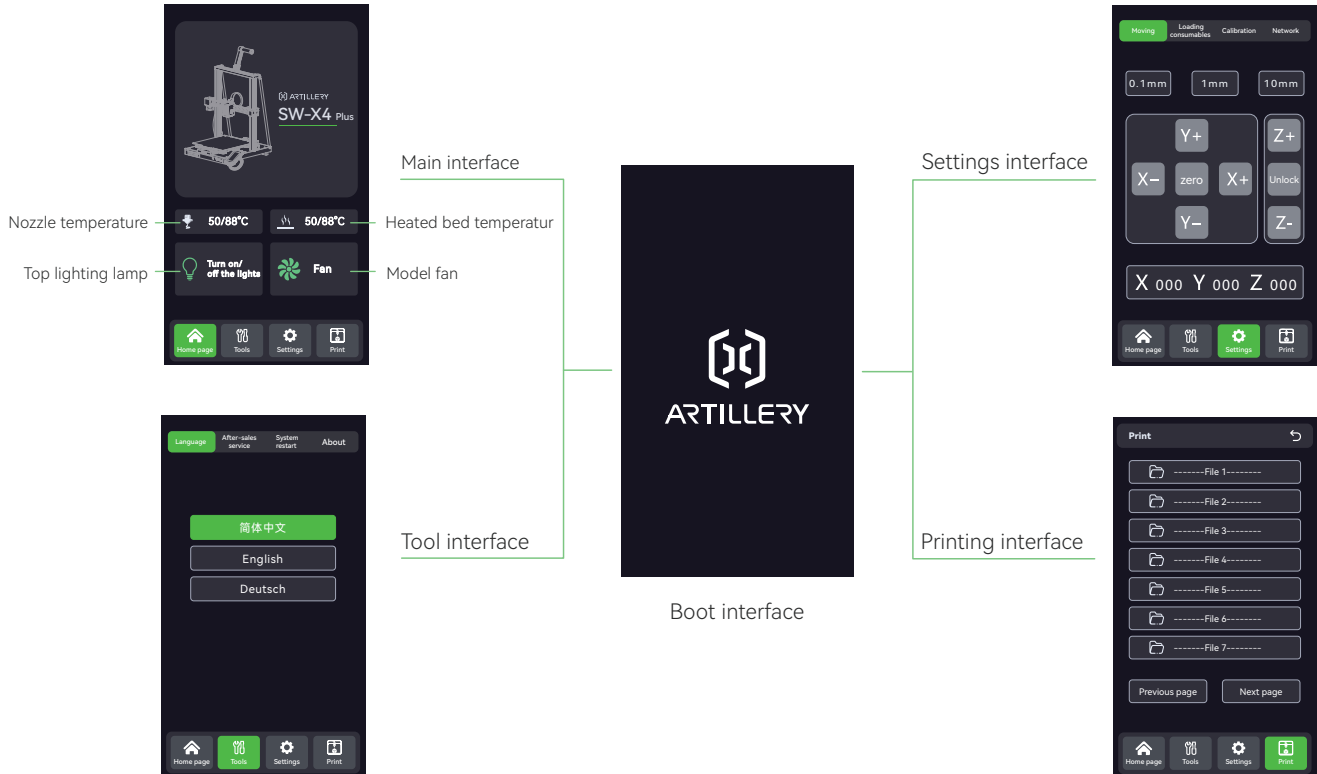

3. Introduction to the Equipment Screen Interface

3.2 Common Functions



3. Introduction to the Equipment Screen Interface

Print main interface

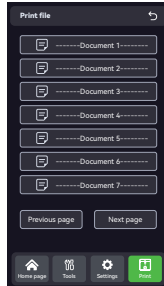
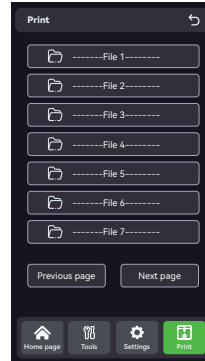

Print file page

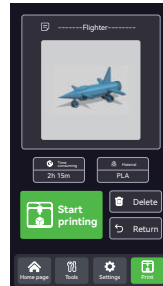

Print page

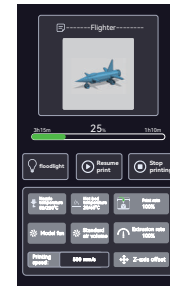

Printing page

3. Introduction to the Equipment Screen Interface

3.3 Boot Guide

1 When starting the machine for the first time, it enters the boot program. Please follow the prompts on the screen.

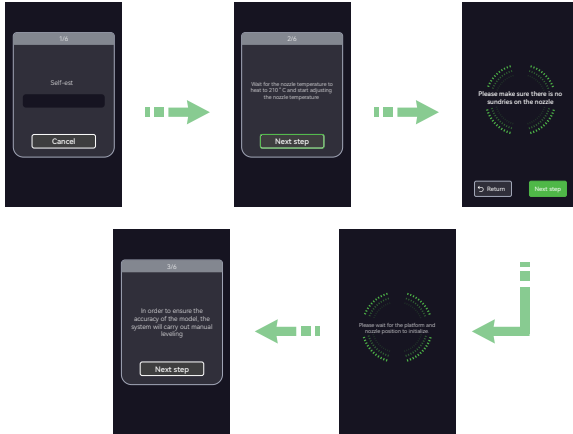

2 Place a piece of A4 paper between the nozzle and the hot bed, move the nozzle to 7 points in turn by operating the touch screen. Adjust the knob at the bottom of the hot bed to ensure that the height from the nozzle at seven points to the printing platform is about the thickness of A4 paper (0.08-0.1 mm) and click "Next" after completion.

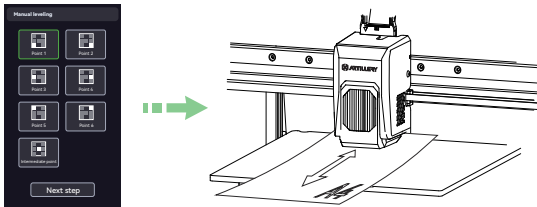

3 Operate according to the screen interface prompts, and wait for the platform and nozzle position to be initialized.

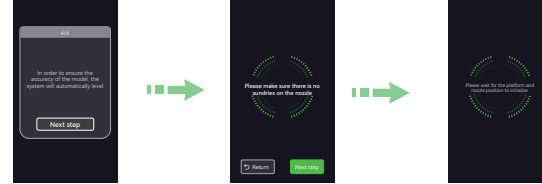

4 Before adjusting the Z offset, tap "Z=0", and if you find that the nozzle is still pressed to the hot bed, tap "Zoffset=0" again. And carry out the "Z=0" offset step, and adjust the Z axis to move up and down, so that the height from the nozzle to the platform is about the thickness of A4 paper (0.08-0.1 mm), and there is obvious friction feeling when drawing A4 paper. Click next and wait for the automatic leveling step to end.



5 After the consumables are loaded into the feeding hole and extruded smoothly, click "Next" to insert the U disk with printed documents.

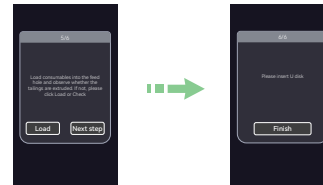

3. Introduction to the Equipment Screen Interface

3.4 Leveling Setting

- 1 First, Tap Zoffset=0, Tap "Settings" → "Calibration" → "Auto Leveling" on the touchscreen. Tap "Z=0". If the nozzle touching the hot bed, then tap "Zoffset=0". Once the adjustments are done, fine-tune the Z-axis offset value up or down until the distance between the nozzle and the hot bed is approximately the thickness of an A4 paper (0.08–0.1mm), with noticeable friction when pulling the paper. Then tap "Save, Return". (Note: If there is no such button, it might be an older version. In that case, tap "Save" first, then tap the return arrow at the top left corner).

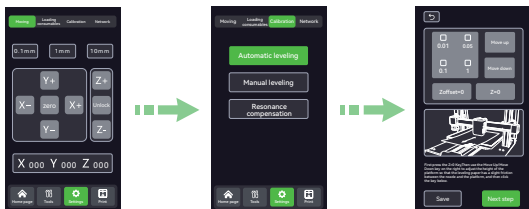

- 2 Manual leveling: Return to zero printer, and click "Set" → "Calibration" → "Manual leveling" on the touch screen.

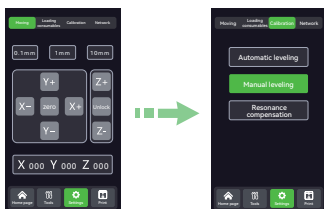

- 3 Place a piece of A4 paper between the heating head and the hot bed.

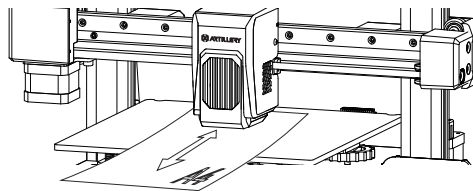

- 4 Move the heating head to 7 points in turn through the touch screen.

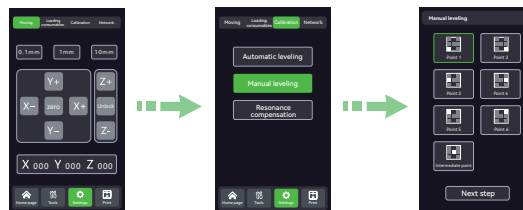

- 5 Adjust the knob at the bottom of the hot bed to ensure that the height from the nozzle at seven points to the printing platform is about the thickness of A4 paper (0.08–0.1 mm).



3. Introduction to the Equipment Screen Interface

- ④ Finally, carry out automatic leveling: click "Set" → "Calibration" → carry out the "Auto-leveling" page to adjust the Z offset. → "Next" on the touch screen for automatic leveling, and wait for the automatic leveling program to end.

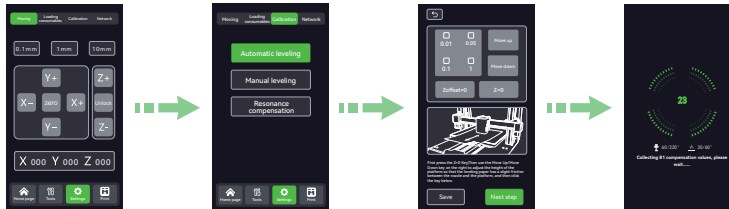

4. Printing for The First Time

4.1 Software Configuration

This printer is compatible with most slicing software, such as Slic3r, Cura, Simplify3D, etc. We'll cover the ArtillerySlicer software in detail and show you how to set it up for the first print.

① Please find the ArtillerySlicer installation package from the random U disk, and start the software for initial configuration after successful installation.

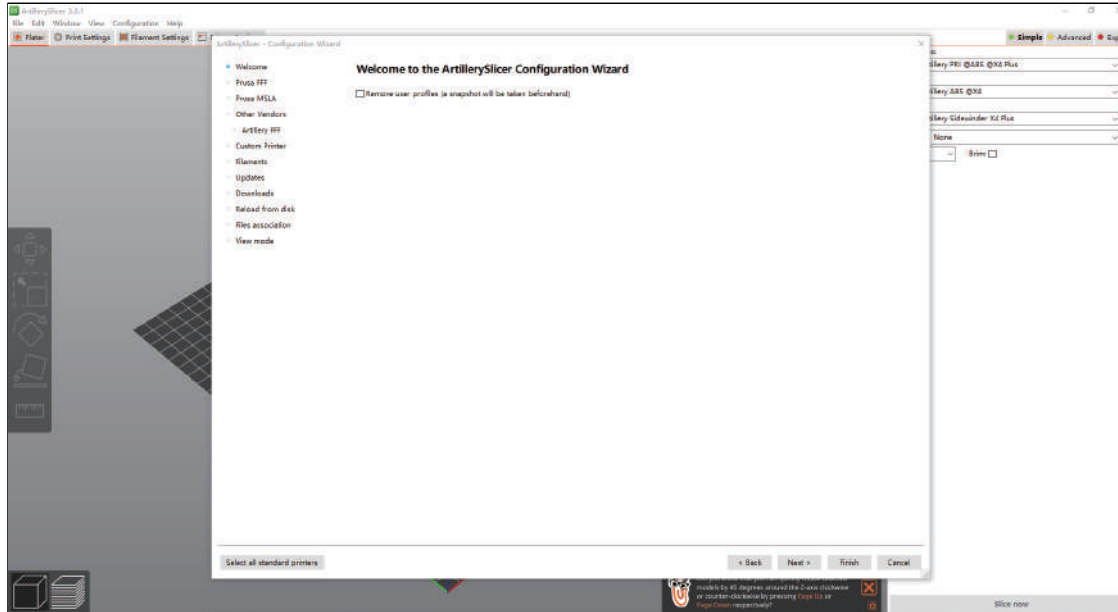

4. Printing for The First Time

- 2 Select "Artillery" brand on the "Other Suppliers" page.

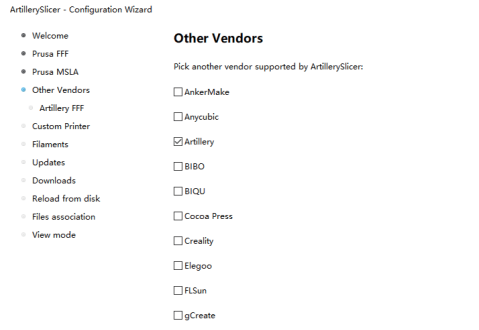

- 3 Select the "Artillery Sidewinder X4 Plus" model in the "Artillery FFF Technology Printer" page.



- 4 Keep the default selection on the "Custom Printer Setting" page and click "Next".

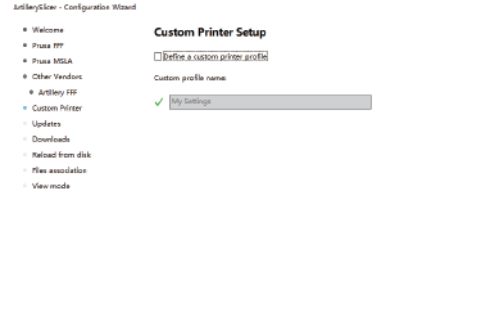

- 5 Select the corresponding printer model and material configuration in the "Consumables Configuration Selection" page (for example, as shown in the following figure).

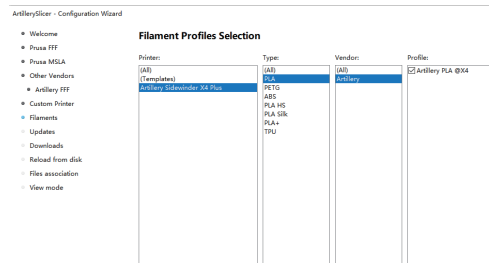

4. Printing for The First Time

- 6 Keep the default selection in the "Automatic Updates" page and "View Page" page.

ArtillerySlicer - Configuration Wizard

- Welcome
- Prusa FFF
- Prusa MSLA
- Other Vendors
- Artillery FFF
- Custom Printer
- Filaments
- Updates
- Downloads
- Reload from disk
- Files association
- View mode

Automatic updates

Check for application updates

If enabled, ArtillerySlicer checks for new application versions online. When a new version becomes available, a notification is displayed at the next application startup (never during program usage). This is only a notification mechanism, no automatic installation is done.

Update built-in Presets automatically

If enabled, ArtillerySlicer downloads updates of built-in system presets in the background. These updates are downloaded into a separate temporary location. When a new preset version becomes available it is offered at application startup.

Updates are never applied without user's consent and never overwrite user's customized settings.

Additionally, a backup snapshot of the whole configuration is created before an update is applied.

ArtillerySlicer - Configuration Wizard

- Welcome
- Prusa FFF
- Prusa MSLA
- Other Vendors
- Artillery FFF
- Custom Printer
- Filaments
- Updates
- Downloads
- Reload from disk
- Files association
- View mode

View mode

PrusaSlicer's user interfaces comes in three variants: Simple, Advanced, and Expert.

The Simple mode shows only the most frequently used settings relevant for regular 3D printing. The other two offer progressively more sophisticated fine-tuning, they are suitable for advanced and expert users, respectively.

- Simple mode
- Advanced mode
- Expert mode

The size of the object can be specified in inches

- Use inches

- 7 Select the corresponding model in the "Printer Settings" page.

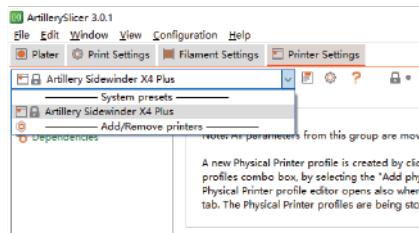

- 8 Select the corresponding materials on the "Filament Settings" page.

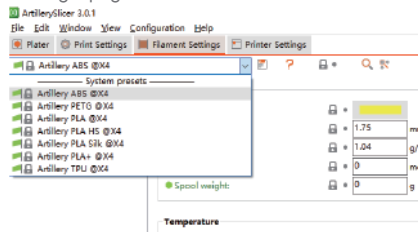

- 9 Select the corresponding parameters on the "Print Settings" page.

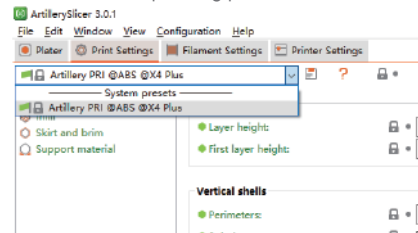

4. Printing for The First Time

4.2 Printing Files

- 1 Select the "Plater" page in the menu bar.

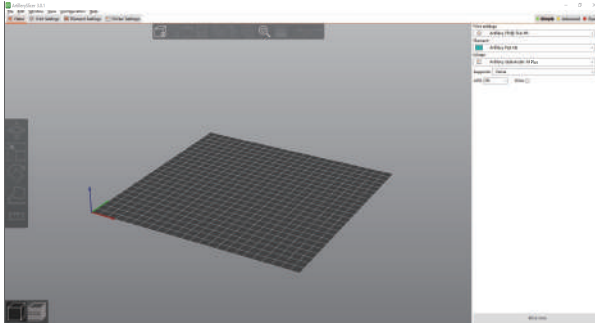

- 2 Drag and drop STL files (or other supported formats) to slicing software, or select "File" -> "Import" -> Import corresponding model files in the menu bar. Click the "Slice Now" key in the lower right corner to slice the model.

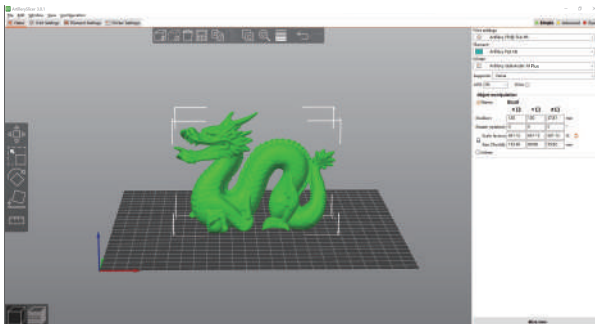

- 3 Data such as printing time and consumables will be displayed after the model slicing is completed. After checking that there is no problem with the slice model, click "Export G-code" in the lower right corner and press the key to export the file.

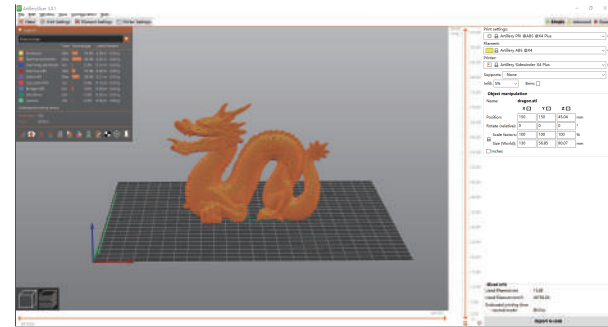

- 4 Click the "Save" .

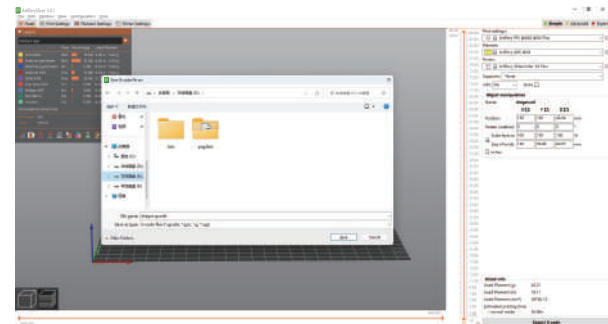

4. Printing for The First Time

- 5 Insert the USB disk into the USB interface of the printer.
- 6 Enter the printing interface and select the file to be printed. After confirming that the file is correct, select and click the "Start Printing" key.
- 7 When the hot bed reach the given temperature, the X, Y and Z axes return to zero, after the nozzle is warmed up and print automatically.

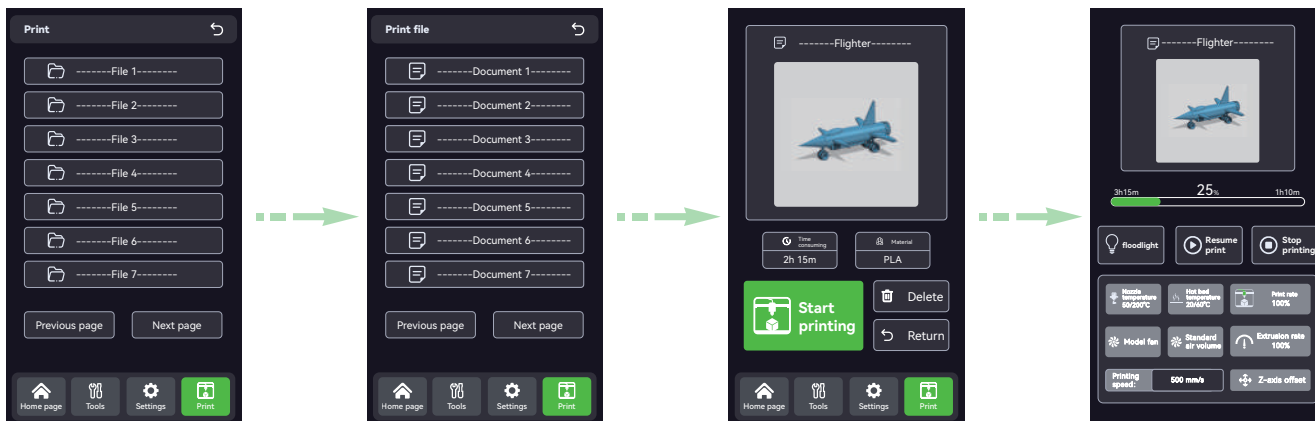

4. Printing for The First Time

4.3 WIFI Connection Printing

In addition to printing through a USB flash drive, printing can also be controlled by connecting to WIFI:

- 1 The original IP is 0.0.0.0. After the printer successfully connects to WIFI, click "📶". The screen page will display the new IP address, please remember this IP address.

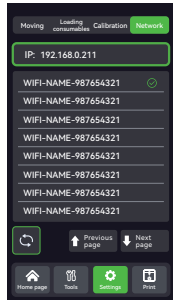

- 2 Enter the IP address in the computer browser and open it, as shown in the following figure: (The printer and computer end need to be connected to the same WIFI)

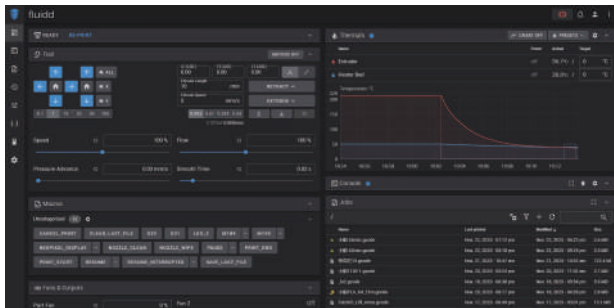

- 3 Click "⊕" in the "Task List" to upload the required slice file. (File suffix is gcode)

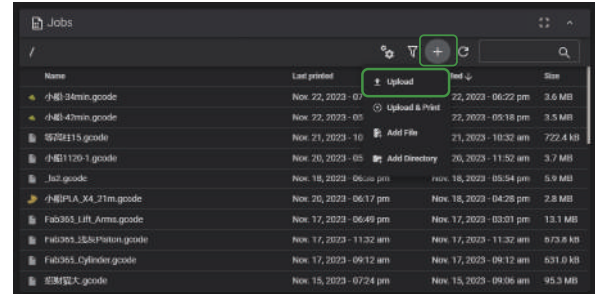

- 4 Right click on the file to be printed in the "Task List" and click "Print". The printer will print on its own.

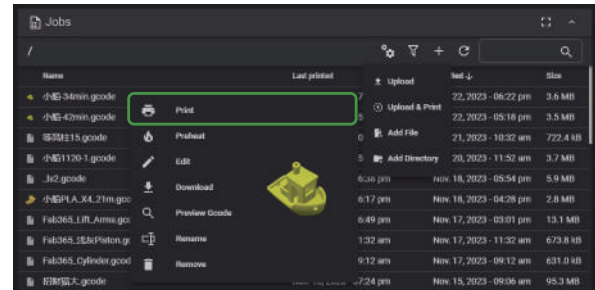

5. Machine Function Explanation

5.1 Feed

1 Hang the consumables on the rack.

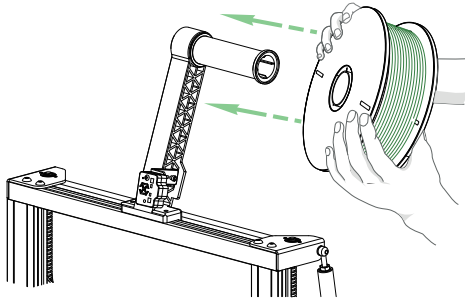

2 In order to feed smoothly, the end position of consumables should be obliquely cut 45 degrees, as shown in the figure.

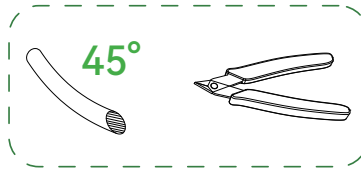

3 After the consumable passes through the broken material detection module, it is inserted into the feeding inlet of the extruder.

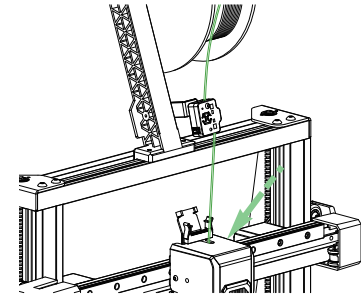

4 Click "Set" → "Load Consumables" → "Feed", and the feeding operation is carried out after the nozzle reaches the established temperature.

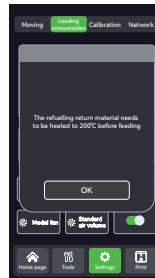
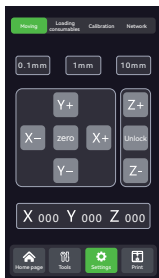

5 When you see consumables flowing out of the nozzle, the loading is completed.

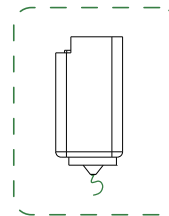

5. Machine Function Explanation

5.2 Material Retraction

1 Click "Set" → "Load Consumables" → "Return Materials" After the nozzle reaches the established temperature, return materials.

2 After preheating the nozzle, click "Return Material", squeeze the consumables downward and then pull them out upward.

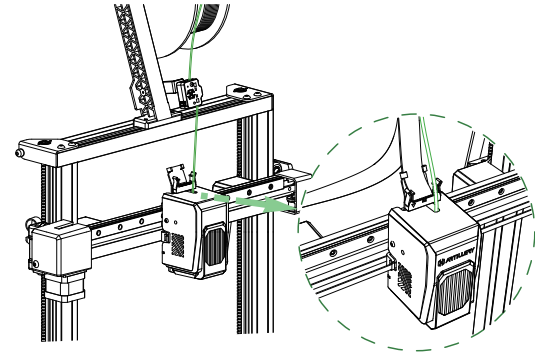

6. Warmly Reminding and Daily Maintenance

6.1 Printing Precautions

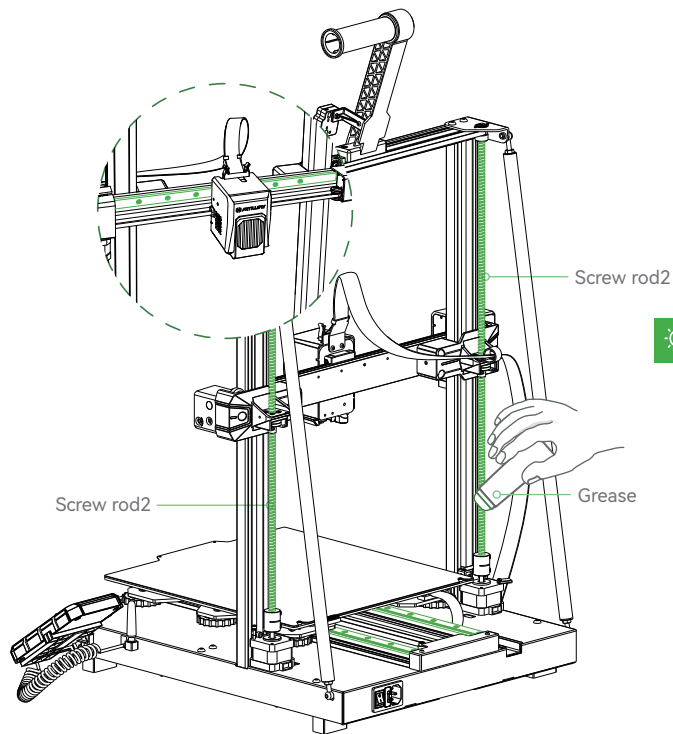

300-hour regular maintenance: Please regularly lubricate the green area in the drawing. Grease only needs to be applied to the middle part, and the machine will automatically apply it evenly through movement. (Users can buy their own grease to maintain the machine.)

6. Warmly Reminding and Daily Maintenance

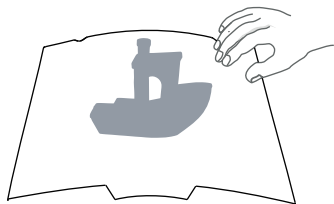

- 1 Wait for the printed model to cool down and pick out from internal equipment with the flexible platform, and the platform is slightly curved in parts to make the model and platform separated. (The platform shouldn't be bent too much to prevent the platform from being deformed and unusable)

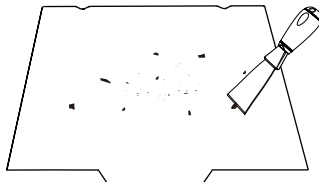

- 2 Remains of platform consumables can be scraped off with a blade. Pay attention to safety when using.

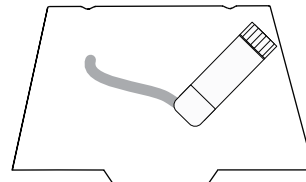

- 3 When printing small models, it is recommended to evenly apply adhesive gel on the surface of the platform, which is helpful to improve the viscosity of the first layer of model printing.

- 4 Clean the sundries on the printer surface regularly.

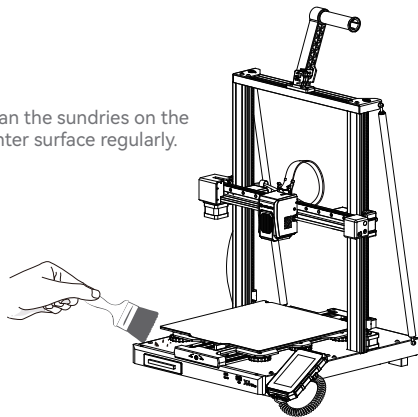

Warmly reminding: when the device has been printed for more than 300 hours or the printing platform or nozzle has been replaced, the distance between the platform and the nozzle maybe changed so that the first layer of the model is not pasted firmly, resulting in printing failed, please calibrate the platform regularly.



Warmly reminding: the printing platform is a consumable part. It is recommended to replace it regularly to ensure that the first layer of the model is attached.

6. Warmly Reminding and Daily Maintenance

6.2 Maintenance Projects

In the process of use, if there is no solution to the problem:

- ① You can log in the official website of ARTILLERY (www.artillery3d.com) to find information on software and hardware, contact information, equipment operation, equipment maintenance, etc.
- ② Alternatively, please contact us according to the phone number and email provided at the end of the manual.

Maintenance Instructions		
Machine Cleaning	Clean up debris inside the machine to ensure that machine movement is not affected.	Every time before printing
Nozzle	When the nozzle is blocked, after preheating and pulling out the consumables, increase the temperature of the nozzle, and use the through needle to pinch the extruder from top to bottom until the consumables are poked out.	After each one time replacement of consumables
	Check whether the wire is normal. If it is not normal, please check whether it is blocked.	
	Check the nozzle for residual material and if so, remove with a tool after heating the nozzle.	
Printing Platform	Check whether there are residual consumables and glue on the surface of the platform, and if so, clean the surface of the platform.	Every time before printing
Motion Mechanism	XYZ shafts and screw rod lubrication.	Cumulative printing time of every 500 hours
Equipment Self-inspection	Vibration optimization.	Cumulative printing time of every 300 hours
	Automatic leveling.	Cumulative printing time of every 300 hours
Consumable Replacement	Replacement of the same type of consumables: follow the normal return-feed process.	
	Replacement of different consumables: the nozzle is preheated to the target temperature of the current consumables - return the material and replace it with the target consumables material, preheat the nozzle to the higher of the two consumables, nozzle temperature - feed for 30s, until the remaining consumable is fully extruded, set the nozzle temperature to the current consumable nozzle temperature, complete.	

6. Warmly Reminding and Daily Maintenance

6.3 Legal Explanation

1.Warranty

The company provides a one-year warranty for the Artillery Sidewinder-X4 Plus 3D printer, the detail contents and rules, please check www.artillery3d.com. If you need after-sales service, you can enter relevant information and submit an after-sales work order through the following website: 1. After sales work order: <https://evnovo.zohodesk.com/portal/en/newticket> 2. Facebook: <https://www.facebook.com/artillery3d>

2.Overall Specifications

All information in this user manual ("Manual") is subject to change at any time without notice and is provided for convenience only. Shenzhen Yuntu Chuangzhi Technology Co., Ltd. and their respective affiliates and suppliers (hereinafter referred to as "Artillery") reserves the right to modify or revise this manual at any time in its sole discretion and makes no commitment to provide any such changes, updates, enhancements or other supplements to this manual in a timely manner or at all.

You agree to be bound by any modifications and/or revisions. Please visit the official website at www.artillery3d.cn for the latest product information.

3.Intellectual Property Right

The design of this manual as well as all text, graphics, information, content and other materials are protected by copyright and other laws. Content copyright belongs to Artillery. Certain trademarks, trade names and logos used in this manual ("Trademark") is a registered and unregistered trademark, trade name of Artillery and its affiliates. Nothing in this manual may be granted or construed by implication, estoppel, or otherwise without written permission from Artillery becomes the grant of any license or use right. Unauthorized use of any information, materials, or markings may violate copyright laws, trademark laws, privacy and publicity laws, and/or other laws and regulations.

4.Disclaimer

Artillery does not warrant the accuracy or completeness of the information, products or services presented in or through this brochure and disclaims all responsibility for any typographical, technical or other inaccuracies in this brochure, or any implied warranty of any kind, including warranties of merchantability, fitness for a particular purpose, or non-infringement of intellectual property rights. As far as your use of this manual is concerned, even if Artillery has been advised of any possible cause in no event shall Artillery be liable to you for direct or indirect, economic, commercial, special, consequential, incidental, exemplary or consequential damages. Such damage includes, but is not limited to, operating income or loss of revenue, data, or profit. For any damage or any virus to your computer, telecommunications equipment, or other property caused by or due to your download of any information or material relating to this manual or malware infection, Artillery assumes no responsibility. The above exclusion clauses do not apply to the scope prohibited by law. Please refer to your local law. Once you use this product, it is assumed that you have read disclaimers and warning carefully, understand, acknowledge and accept all terms and content of this statement. You promise that you are solely responsible for the use of this product and the consequences it may cause. You promise to use this product only for proper purposes, and agree to these terms and any related regulations, policies and guidelines which specified by Artillery.



Artillery Co., Limited

Email: support@artillery3d.com

Website: www.artillery3d.com